

## Impact Loading of Plates: Validation of Numerical Simulations by Testing

Magnus Langseth, Odd Sture Hopperstad and Torodd Berstad

Department of Structural Engineering, Norwegian University of Science and Technology, Trondheim, Norway

### ABSTRACT

Impact tests performed on steel and aluminium plates in the low-velocity regime, i.e.,  $v_i < 50$  m/s, were used to validate numerical simulations performed with the computer code LS-DYNA. Good agreement was found for the steel plates grade St52-3N by using the quasi-static material properties and shell elements. For the aluminium plates, alloys AA5083-H112 and AA6082-T6, some difference between analyses and tests was found and more research has to be carried out before general conclusions and recommendations can be made.

### INTRODUCTION

According to several design codes and regulations, dropped objects shall be considered in the design of offshore structures. Based on a survey of possible dropped objects, long rods such as drill-collars are identified as the most dangerous items due to their high kinetic energy and small contact area with the structure during impact. A drill-collar has a mass of approximately 3,200 kg, a length of 10 m, a diameter in the threaded pin end of 146 mm and may be dropped from heights up to 40-50 m (Fig 1a).

The response of steel and aluminium plates subjected to a dropped drill-collar is described by global deformations of the plates combined with the possibility of a local failure at the impact point. This combined mechanism makes the design very difficult and has therefore mainly been based on full-scale testing. To improve the understanding of the response of steel and aluminium plates subjected to large-mass projectiles in the low-velocity regime ( $v_i < 50$  m/s), a model test study has been carried out (Langseth and Larsen, 1990, 1993, 1994). Rigid-body blunt-ended projectiles were fired against steel and aluminium plates in order to study the plugging capacity of such targets and to develop design recommendations. The primary variables were the target thickness, mass of the projectile relative to the mass of the target plate, and the support conditions.

In order to extend the parametric range of the proposed design recommendations (Langseth and Larsen, 1988, 1992; Veritec Report, 1988) and to get a better understanding of the physical mechanisms present during impact, numerical simulations can be used. However, before such analyses can be considered reliable the predictions have to be validated against test data. Therefore, the main objective of this paper is to investigate if the response of thin steel and aluminium plates subjected to large mass-projectiles in the low-velocity regime can be predicted by using the computer code LS-DYNA (Hallquist, 1991).

### LABORATORY TESTS

A short summary of the experiments carried out by Langseth and Larsen (1990, 1993, 1994) will be given here as a basis for the comparison between the experimental results and the LS-

DYNA calculations.

All tests were carried out in scale 1:4 using replica modelling. Table 1 shows the tests used in the present validation programme. The structural model for the impacted steel plates was chosen as clamped plates with stringers (test series DM) and simply supported hatches (test series A1, B1) of the same type as used in the wellhead area on a platform for simultaneous drilling and production.

As a structural model for the aluminium plates (test series E1 and E2), only simply supported hatches with the same geometry as that used for steel were chosen.

For the present tests the drill-collar was modelled as a rigid body (Fig. 1b) with a flat-ended circular nose. Throughout the tests the diameter of the projectile was taken as  $d = 36.5$  mm, which is the scaled diameter of the threaded pin end. All tests were carried out using a pneumatic accelerator.

The material properties for the steel plates at elevated rates of strain were determined by tension tests (Langseth et al., 1991), Fig. 2. Only quasi-static tests were carried out for the aluminium plates as the material was assumed to be strain rate insensitive (Lindholm et al., 1971), Fig. 3.

The projectile was instrumented by strain gauges that were used to record the interface force between projectile and target. Based on this force-time history, the displacement of the projec-

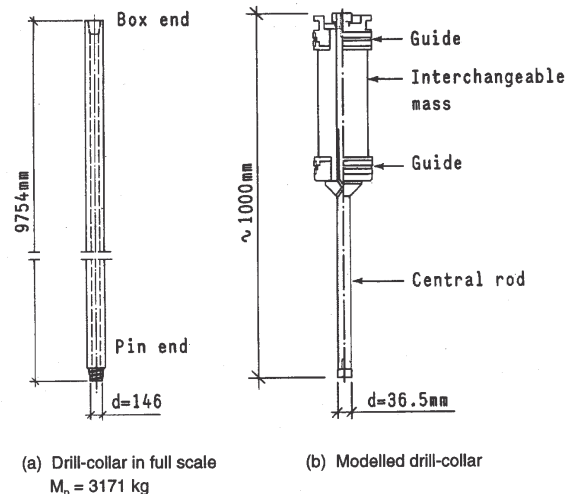

Fig. 1 Drill-collar modelling

Received May 17, 1997; revised manuscript received by the editors November 5, 1998. The original version (prior to the final revised manuscript) was presented at the Seventh International Offshore and Polar Engineering Conference (ISOPE-97), Honolulu, USA, May 25-30, 1997.

KEY WORDS: Validation, plates, steel, aluminium, impact.