

Reliability Analysis of Production Ships

Xiaozhi Wang* and Torgeir Moan
Division of Marine Structures, The Norwegian Institute of Technology
Trondheim, Norway

Guoyang Jiao
SINTEF Structures and Concrete, Trondheim, Norway

ABSTRACT

Reliability analysis of bottom panels of production ships is performed. Probabilistic models are used for still water bending moment (SWBM), vertical wave bending moment (VWBM) and dynamic pressure. A load combination factor is introduced for the combination of SWBM and VWBM based on observed ship operational data and stochastic process theory. The beam-column approach is applied for design of longitudinally stiffened panels simultaneously subjected to axial compressive stress arising from the global bending moments and local bending stress caused by lateral pressure. Probabilistic model uncertainty for the interaction model is included. The hogging condition is considered. Implied safety levels in DnV rules are estimated by considering various design cases. A more rational design format is then proposed. The corresponding load factors are calibrated based on rationally selected target safety levels. Uniform safety levels are achieved through calibration.

INTRODUCTION

Ships are attractive as production facilities for offshore hydrocarbons for small fields or even large fields during early production. A typical production ship is shown in Fig. 1. Such ships operate in different modes from oceangoing merchant vessels. For instance, production vessels are normally operated in designated regions, have zero speed and are held head on waves. Moreover, they are designed to encounter the most severe sea states, while merchant vessels are supposed to avoid heavy weather. These and other factors make both still water and wave responses different from those of merchant vessels. Also there are reasons for differentiations of the safety levels for offshore production ships and oceangoing merchant vessels. This calls for a rational assessment of design criteria for vessels used in offshore operations.

As a very important part of the ship hull girder, design of the ship bottom structure is very critical to the integrity of ship structure. Under a combination of still water bending moment, vertical wave induced bending moment, static pressure and wave induced dynamic pressure, buckling of plates or stiffeners of a typical bottom panel, as shown in Fig. 2, is generally regarded as a critical failure mode. To ensure a safe design of the bottom structure, it is thus necessary to account for various uncertainties associated with the applied loads, load effects, material properties, as well as response and capacity models.

The maximum still water and wave responses do not necessarily occur at the same time. A stochastic process theory may then be applied to calculate the maximum design value of the combined still water and wave responses. In the design of the bottom structure, the interaction and correlation between the global longitudinal hull girder stresses arising from still water and wave loads,

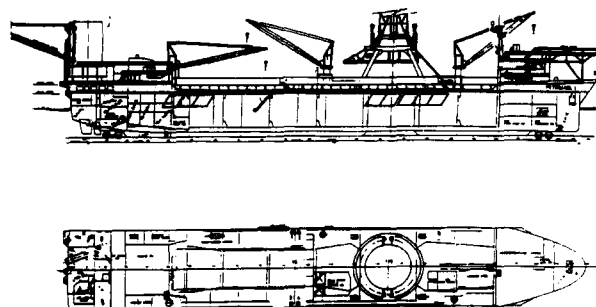

Fig. 1 Illustration of production ship

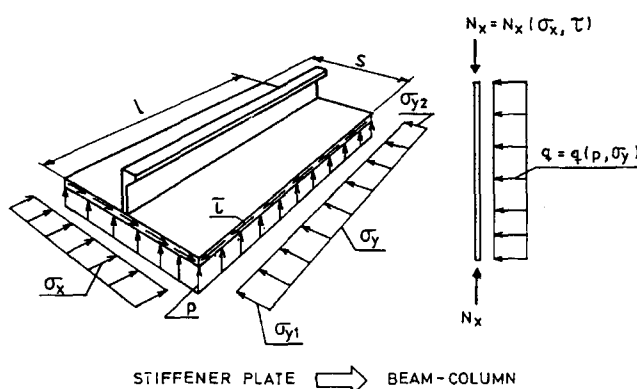

Fig. 2 Model of ship bottom panel subjected to axial compression and bending

and the local bending stresses arising from lateral pressure, should also be accounted for in a rational analysis.

To establish a sound basis for design criteria for purpose-built production vessels structural reliability analyses were accomplished and are reported in Moan (1988). That study aimed at code development for production vessels at large and was based on generic values of uncertainty measures. The purpose of this

*ISOPE Member.

Received March 1, 1993; revised manuscript received by the editors August 15, 1994. The original version (prior to the final revised manuscript) was presented at the Third International Offshore and Polar Engineering Conference (ISOPE-93), Singapore, June 6-11, 1993.

KEY WORDS: Still water, wave, bending moment, pressure, load combination, buckling, limit state, calibration.